



Welbee

Welbee Inverter

A350P

AC/DC Pulsed TIG Welding
Power Source

- 3 Advanced TIG Modes: AC Pulse / DC / AC+DC Hybrid Pulse
- Exclusive AC+DC Hybrid Pulse combines the cleaning action of AC pulse with the speed & penetration of DC, resulting in faster travel speeds, smaller beads, and deeper weld penetration.
- Improved duty cycle achieves high-efficiency welding with AC pulse frequencies up to 500Hz.
- *Welding Setting Guide* drives simple, automatic setting of the welding condition.
- Fieldbus network I/O support for easy, plug-and-play interface to your automation.



Versatility that delivers high-quality welds ranging from ultra-thin sheet to thick plate. Because your most critical applications require the best, most consistent welds.

DAIHEN Corporation

A350P

AC pulse welding mode for high-quality welds on all materials and thicknesses.

High-quality welding on ultra-thin sheet

Arc stability in the low-current zone (min. current for AC output: **5A**) and superior arc-concentration (max. AC pulse frequency: **500 Hz**).

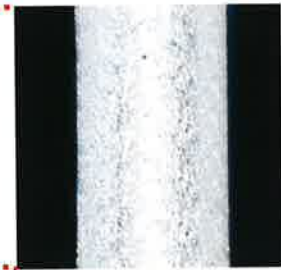
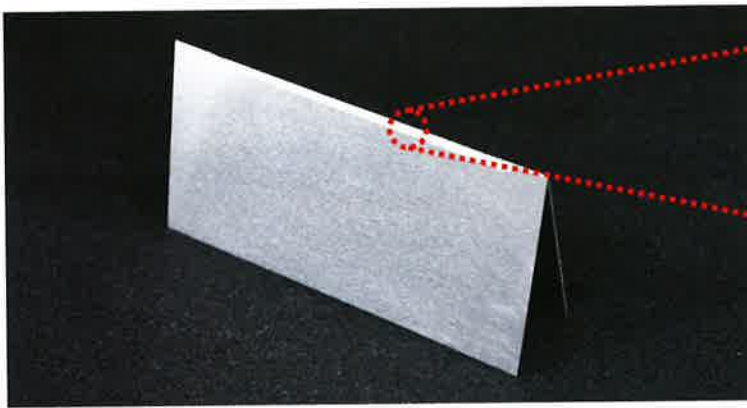

Consistent welds without burn-through

Base metal: soft aluminum; sheet thickness: 0.2mm; Ar 100%; current: 5A; Welding speed: 7cm/min; AC pulse frequency: 500Hz

Industry's highest AC pulse frequency = industry's tightest arc concentration

Tight arc concentration produced at an AC pulse frequency of **500 Hz** drives deeper penetration and stronger welded joints.

Faster arc starts with near-instantaneous weld pool formation result in **3X quicker tack welds**.

■ Deeper weld penetration at the same weld current.

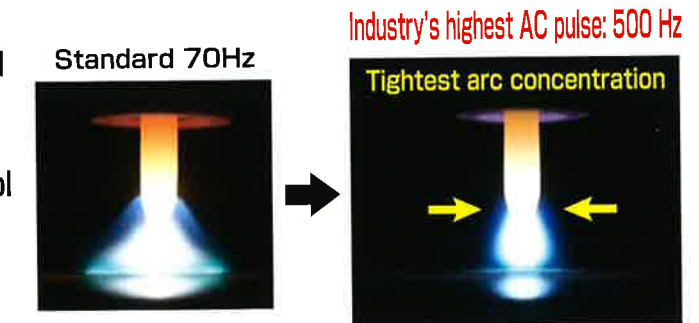
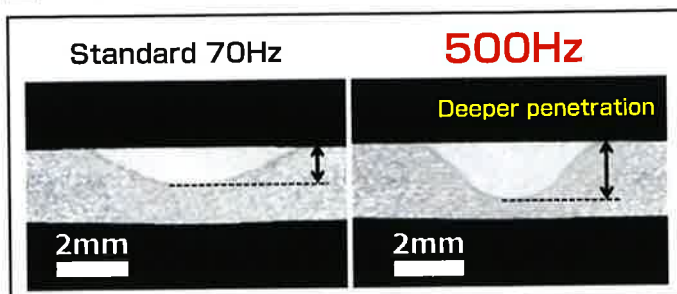

■ Near-instantaneous weld pool formation speeds tack welds up to 3X conventional welders.

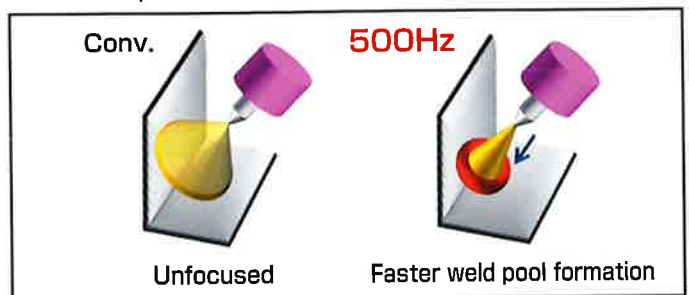



Advanced TIG modes

3 Advanced TIG modes are available :
AC pulse / DC / AC+DC hybrid pulse

AC+DC hybrid pulse mode

alternately outputs the AC period in which cleaning action is obtained and the DC period in which deep penetration is obtained.

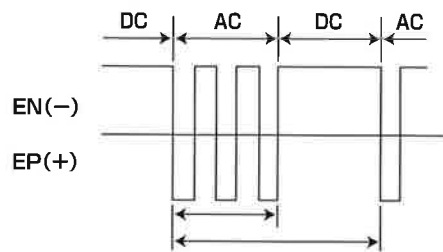

Improved duty cycle supports thicker plate welds

Higher duty cycle (max. output: 350A, continuous welding current: 270A), enables multi-pass welding on thick plates.



Base metal: hard aluminum, 10-mm thick plate, Ar 100%

-1st layer:

Straight run, AC240A (filler wire feed rate: 2.7m/min, welding speed: 30cm/min, AC frequency: 500Hz)

-2nd layer:

Weaving run, AC220A (filler wire feed rate: 3.0m/min, welding speed: 12cm/min, AC frequency: 150Hz)

-3rd layer:

Weaving run, AC200A (filler wire feed rate: 3.5m/min, welding speed: 10cm/min, AC frequency: 70Hz)

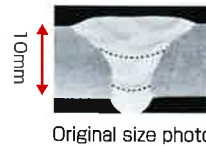

Original size photo

Higher current rating and a wider usable current range at 100% duty cycle outpace conventional TIG welders.

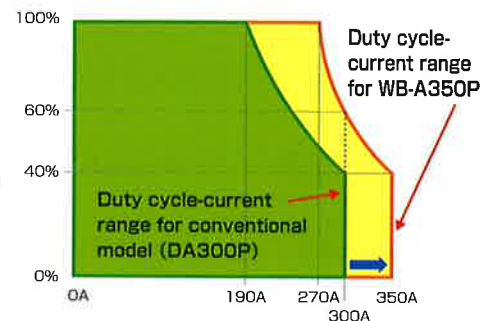

Fine adjustment (0.1A increments) at the low current range (2.0A - 10.0A) optimizes current setting of the best weld condition for ultra-thin sheet

Weld results vs. fine current adjustments

SUS304, 0.3-mm thick plate butt joint, DC mode

A350P Amp:8.5A



Meandered weld bead due to heat input shortage.



Stable weld bead obtained by fine amp control.



Burn-through caused by excessive heat input

1A increments

Amp:8A

Amp:9A

TIG interval function modulates heat input to prevent thermal strain and burn-through on ultra-thin sheet

The interval function eliminates the need to repeatedly activate/deactivate the torch switch to adjust heat input. Arc-ON and Arc-OFF times are fully programmable to semi-automatically achieve the ideal heat input and "stacked-dime" bead appearance for your ultra-thin sheet application.

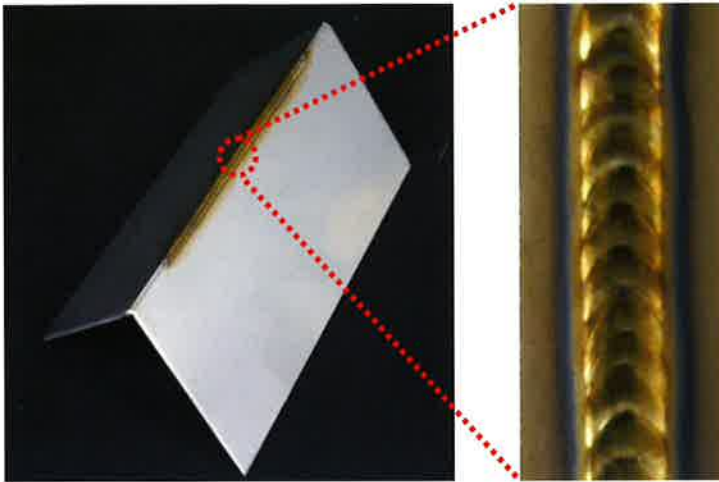

Note: High frequency wave is initiated at Arc-ON. Touch start is disabled.

Programmable Arc-ON and Arc-OFF time intervals

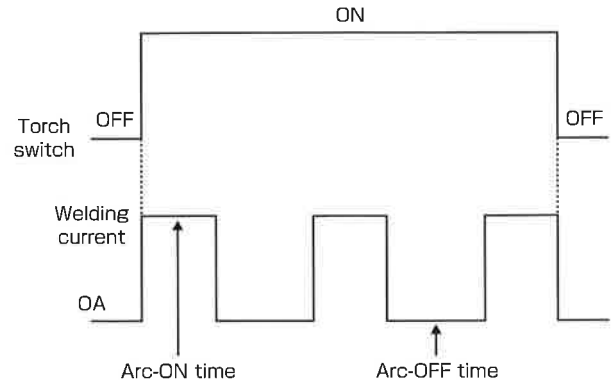

Welding Current Adjusting Function of the torch switch

Welding Current Adjusting Function allows the increase or decrease of the output current via torch switch operation.

Step-level increase/decrease amount is programmable.

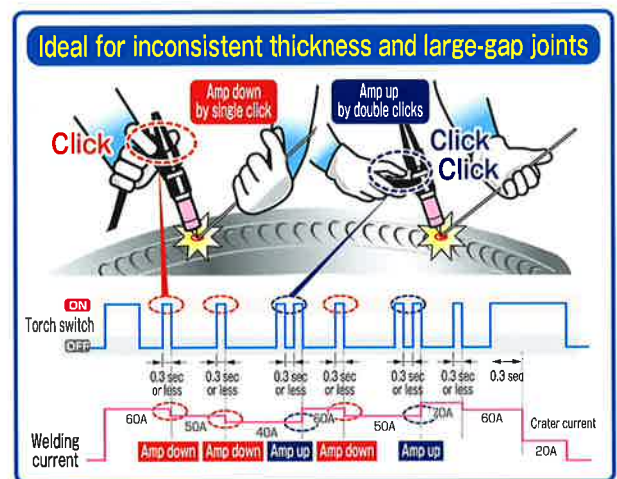

AC manual welding mode for covered electrodes

- Supports covered electrode welding in both AC and DC manual welding mode.
- Improved operation via the ON/OFF function of the torch switch.

Note: When using the AC manual welding mode, see Article 332 of the Ordinance on Industrial Safety and Health, installing the voltage reducing device if necessary. (voltage reducing device K-300 requires K970J77 mounting bracket)

WELBEE: Designed for durability and easy maintenance

Side-air-flow structure

- Best protection for the precision components

Precision components including the WELBEE processor, are mounted in a sealed area within the weld power source housing, protected from the harsh welding environment.

- Wind tunnel design for reliable operation and simple maintenance

Cooling fans incorporate a side-flow design, operating automatically based on the duty cycle and ambient temperature. Preventative maintenance using compressed air from front-to-rear simply and easily removes and accumulated debris from the lower, power inverter area.

Precision parts area



Dust penetration into precision components is reduced by about 98%

Cable-extension (AC TIG mode and AC+DC TIG mode)

Optional mode where the torch cable can be extended up to 50m from the weld power source.

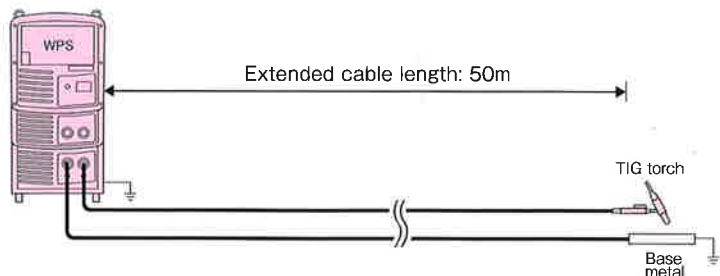

Note: AC frequency is limited to maximum of 100 Hz with this option

Welding Setting Guide for automatic setting of welding conditions

Quick and simple setup of your WPS condition

Automatic assistance in setting welding conditions such as welding current, initial current, and crater current, by setting four (4) key application parameters:

- 1) Electrode diameter
- 2) Base metal type
- 3) Weld joint type
- 4) Base metal thickness

Simplifying the setup of our WPS condition including pulse parameters, saving time and streamlining the initialization process for new jobs.



1 Electrode dia.(Choice: 1.6, 2.4, 3.2, 4.0, 4.8, or 6.4 mmφ)

3 Weld joint type(T fillet, Butt, Lap fillet, Corner)

2 Base metal type(Al, Mild steel, Stainless steel)

4 Base metal thickness (0.5 mm or thicker)

Set these **four (4)** key application parameters and the suitable welding conditions will be automatically set.

How to use the *Welding Setting Guide*

1 Select the Welding Method button

A Select **AC TIG** or **DC TIG**.

2 Select the Welding Setting Guide button to set the four (4) key application parameters: (electrode dia., base metal type, weld joint type, and base metal thickness)

Proper setting of the weld condition is complete.

Welding Management monitors and detects welding abnormalities during operation

Monitor and detect weld quality & quantity to deliver **welding quality management** through automatic alarming of welding abnormalities.

Actively monitors and reports on sixteen (16) weld quality and quantity parameters to aid quality management by your welders.



Weld Monitored Items

Settings for monitoring and detection of abnormalities

Quality Management	Mgmt item	Welding management data
Weld Abnormality and Early Detection	Weld quality	Welding Amps / Volts average value
		Plus-side current tolerance (%)
		Minus-side current tolerance (%)
		Welding voltage upper limit (V)
		Welding voltage lower limit (V)
		Abnormality duration time (sec)
Productivity	Total welding time	Welding condition abnormality detected
		Resultant total welding time (min)
		Target welding time (min)
		Target welding time achieved
Weld counter and missing weld detection	Number of welds	Weld counter
		Target count for weld counter
		Weld counter achieved

Fieldbus interface for use with automation / robotics

Fieldbus connection tool for digital I/O communication with automation logic controller or conventional robot controller

Network I/O Interface

IFR-800EI
IFR-800PB

EtherNet/IP interface
PROFIBUS interface

Fieldbus connection tool catalog (Japanese)



Connection diagram This color is a standard composition.

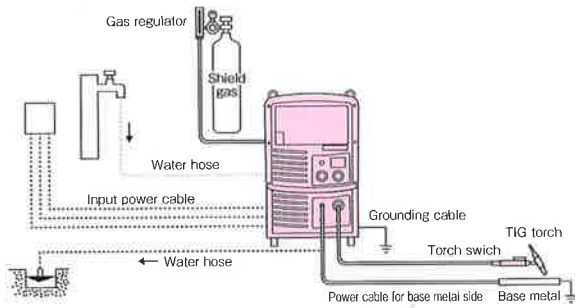

Power supply equipment capacity and connection cable

項目	機種		WB-A350P
Input voltage	V	V	400±15%
Number of phase	-	-	Three phase
Input power capacity	kVA	kVA	16 or more
Capacity of distribution box	Switch with fuse	A	20
	Earth leakage breaker ※1 No fuse breaker	A	20
※2 Input side cable	mm ²		4 or more and 38 or less
Power cable for basemetal side	mm ²		38 or more
※2 Grounding cable	mm ²		4 or more

※1 When using a no-fuse breaker, please use "for motor".
 ※2 Numerical value in parenthesis indicates the size of the welding machine side pressure terminal.
 CE-Marking welding power supplies are equipped with a input cable and a ground cable.
 ※Depending on the area in which a power source is used, the specification is different.

Standard Compositions

Model	Welbee Inverter A350P		
	AWD-17 (Air-cooled)	AWD-26 (Air-cooled)	AWD-18 (Water-cooled)
Welding torch			
Base metal side power cable		BKPD-3803	
Gas hose		BKGF-0603	
Water hose	For tap water	-	BBDW-3001
	For PU-701	-	BBPU-3002
Argon gas regulator		※	

※Depending on the area in which a power source is used, the specification is different.

Standard specifications

Specification/Model		Welbee Inverter A350P			
Model		WB-A350P			
		AC TIG welding	DC TIG welding	AC STICK welding	DC STICK welding
Rated output current	A	350	350	350	350
Rated input voltage	V	400			
Number of phase	-	Three phase			
Rated frequency	Hz	50/60			
Rated input	kVA	12.7(11.1kW)	12.2(10.8kW)	16.3(14.6kW)	16.1(14.5kW)
Maximum no-load voltage	V	74			
Rated duty cycle	%	40		30	
Rated output voltage	V	24	24	34	34
Output current range	A	5~350	2~350	10~350	
Preflow time	sec.	0~99		-	
Afterflow time	sec.	0~99		-	
Up slope time	sec.	0~10		-	
Down slope time	sec.	0~10		-	
Pulse frequency	Hz	0.1~999		-	
Pulse width	%	50 (Modifiable with function keys 5~95%)			
AC frequency	Hz	30~500	-	50 or 60	-
Cleaning width adjustment	%	-20~20 (Percentage of electrode plus period 10~50%)		-	
AC-DC switching frequency	Hz	0.1~50		-	
Crane filler control		OFF/ON/ON (repeat)		-	
Arc spot time	sec.	0.1~10		-	
Number of welding condition memory		100			
External dimensions (W×D×H)	mm	395×710×640 (w/o eyebolt)			
Mass	kg	68			
Starting method		High frequency start/Lift start		-	

※When the AC frequency becomes higher, it may deviate from the set current and the output current.
 ※Depending on the area in which a power source is used, the specification is different.

Welding torch	model	AWD-17	AWD-26	AWD-18
Rated current A	A	150(DC), 130(AC)	200(DC), 160(AC)	350(DC), 270(AC)
Rated duty cycle %	%	50	50	100
Cooling method		Air-cooled	Air-cooled	Water-cooled
Applied electrode diameter	mm	(0.5), (1.0), 1.6, (2.0), (2.4)	(0.5), (1.0), (1.6), (2.0), 2.4, (3.2), (4.0)	(0.5), (1.0), (1.6), (2.0), (2.4), 3.2, (4.0)
Cable length	m	4 or 8		

※When using a tungsten electrode in (), an optional item is required.

Standard accessories

Name	Welbee Inverter A350P
Power cable connector (part number)	1 (4734-016)

Torch standard accessories

Welding torch model	AWD-17	AWD-26	AWD-18
Torch switch	1 (4/8m)	1 (4/8m)	1 (4/8m)
Cable tie	2	2	2

Torch adapter

Model	
For AWD-17	BBAWD-1701
For AWD-26	BBAWD-2601
For AWD-18	BBAWD-1801

Remote controller

Item name	Part No.
Digital remote control	E-2456
CAN communication cable	BKCAN-0405 (5m)
	BKCAN-0410 (10m)
BKCAN conversion connector	K5810B00

Extension cable for remote control

4m	11m	16m
BKCPJ-0404	BKCPJ-0411	BKCPJ-0416

Extension cable for torch

Model	4m	11m	16m
AW(D)-17	BAWE-1504	BAWE-1511	BAWE-1516
AW(D)-26	BAWE-2004	BAWE-2011	BAWE-2016
AW(D)-18	BAWE-3004	BAWE-3011	BAWE-3016

Interface

Item name	Part No.
Fieldbus connection tool (EtherNet/IP type)	IFR-800EI
Fieldbus connection tool (PROFIBUS type)	IFR-800PB

※Please select according to the communication specification on the host side.

Electric shock prevention device

Item name	Part No.
Electric shock prevention device	K-300
Mounting bracket	K970J77
Cable for base metal side	BKPDT-60R1 (0.1m)

※This equipment may be required when using AC STICK mode.

In accordance with DAIHEN's policy to make continuing improvements, design and/or specifications are subject to change without notice and without any obligation on the part of manufacturer.

DAIHEN Corporation

Phone:+81-78-275-2006, Fax:+81-78-845-8159

DAIHEN Inc.

Phone:+1-937-667-0800, Fax:+1-937-667-0885

OTC DAIHEN EUROPE GmbH

Phone:+49-2161-6949710, Fax:+49-2161-6949711

OTC Industrial (Shanghai) Co.,Ltd.

Phone:+49-2161-6949710, Fax:+49-2161-6949711

OTC (Taiwan) Co.,Ltd.

Phone:+886-3-461-3962, Fax:+886-3-434-2394

OTC DAIHEN Asia Co.,Ltd.

Phone:+66-2-714-3201, Fax:+66-2-714-3204

OTC DAIHEN INDIA Pvt.Ltd.

Phone:+91-124-4300821, Fax:+91-124-4300820

PT.OTC DAIHEN INDONESIA

Phone:+6221-2957-7566, Fax:+6221-2957-7567

DAIHEN Korea Co.,Ltd.

Phone:+82-31-686-7459, Fax:+82-31-686-7465